

We are leading name engaged as Manufacturer, Exporter, Supplier and Retailer of wide range of Industrial & Engineering Products, Industrial & Oil Seals, Industrial Pump and Industrial Seals etc...



cartridge chemical process pump



Chemical Process Pump



double mechanical



horizontal pumps



Mechanical Seals



Mechanical Spare Parts

## About Super Industries

Super Mechanical Seal Pvt. Ltd. an ISO 9001:2008 certified Company has always strived to present the latest “ Seal Technology” at Unbelievable Price and great Value added Services to the people we treasure the most like you. We take this opportunity to introduce ourselves as a leading organization having more than three decades of experience in the field of designing and manufacturing of International Quality Mechanical Seals with Proven Performance Capability meeting the requirements of International Market. SUPERs high quality oriented “Mechanical Seals” are suitably designed to fit into every Rotating Equipment like Pumps, Agitators, Mixers, Blowers Compressors etc. catering the needs of virtually all segments of Industries such as– Chemicals, Fertilizers, Petrochemicals, Refineries, Power Stations, Solvent Extraction Plants, Textile & Sugar Industries, handling all kinds of fluids like Acids, Chemicals, Hazardous Corrosive Slurries etc. operating under different temperature and pressure conditions. We have highly qualified and technically trained Engineers in Design & Development as well as Quality Control Department engaged in continuous development to ensure the best quality and to keep the system updated to meet the changing trends of the Global Market. as per norms of latest API 682, 4th edition. SUPERs high quality oriented “Mechanical Seals” are suitably designed to fit into every Rotating Equipment like Pumps, Agitators, Mixers, Blowers Compressors etc. catering the needs of virtually all segments of Industries such as– Chemicals, Fertilizers, Petrochemicals, Refineries, Power Stations, Solvent Extraction Plants, Textile & Sugar Industries, handling all kinds of fluids like Acids, Chemicals, Hazardous Corrosive Slurries etc. operating under different temperature and pressure conditions. We are continuously exporting huge quantity of Mechanical Seals in Gulf countries and hence to meet their service requirement and cope-up the market for new materials, we have set up our full fledged Mechanical Seal manufacturing company at Al-Jubail, Saudi Arabia to provide services to our clients all they need and a little more. We have created new market by replacing our competitors of International Brands in many companies with our most efficiently designed seals which provide total solution to our esteemed clients with matchless consistency and superior performance. For your any leakage problem contact us at our service centre as convenient to you. MECHANICAL SEAL INTRODUCTION The modern trend in process/chemicals industry is an increasing awareness of the use of Mechanical Seals. The maintenance engineer today is more conversant with and appreciative of the benefits obtained by the use of Mechanical Seals compared with gland packing in the stuffing box. Gland packing works on the principle of controlled leakage whereas mechanical seals tend to seal with no visible leakage. The initial cost of a Mechanical Seal is high as compared to gland packings. However the power consumed, maintenance and downtime spent in renewing or tightening the gland packing overweigh the initial cost of a mechanical seal, which works unattended for a long time. From the ecological point of view the environment, because of the absence of visible leakage is clean and hazard free when mechanical seals are used. Today mechanical seals are in demand to seal difficult fluids like acids, strong alkalies and fluids at higher pressures and temperatures. It is important to consider all duty parameters when selecting a suitable

mechanical Seal.

## Factsheet

### Basic Information

Nature of Business	: Manufacturer / Exporter / Supplier / Retailer
Contact Person	: T.P.Tiwari
Registered Address	: Plot No. A-531T.T.C. Industrial Area,M.I.D.C. Mahape,Navi Mumbai – 400 710Maharashtra
Total Number of Employees	: 50 - 100
Year of Establishment	: 1991
Legal Status of Firm	: Individual (Sole proprietorship)

**Industrial Seals**



Teflon Bellow Seal



Rubber Bellow Seal

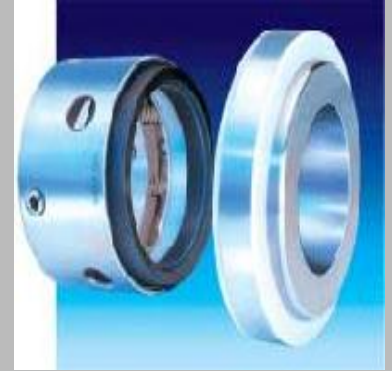

Multi Spring Seal

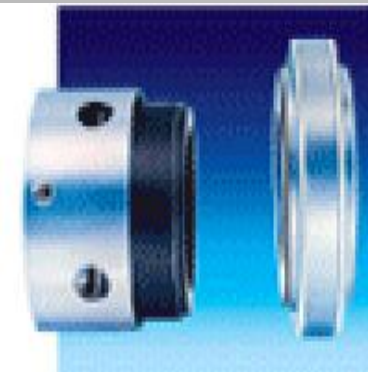

Multi Spring Seal



Double Mechanical Seal



Double Mechanical Seal

## Industrial Pump



vertical centrifugal pumps



horizontal pumps



Chemical Process Pump

cartridge chemical  
process pump

## Industrial &amp; Oil Seals

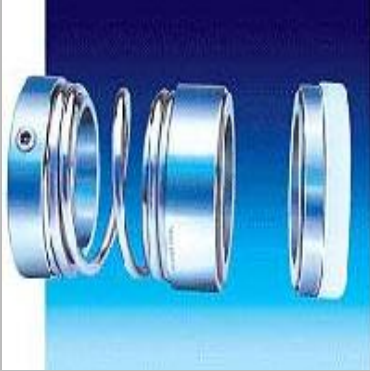

Single Spring Seals Si  
200 Series



Single Spring Seal



Single Spring Seal

## Industrial &amp; Engineering Products



teflon bellow



Mechanical Spare Parts



mechanical seals spares



## Other Products/Services



double mechanical

## Contact Us

**Super Industries**

Contact Person : T.P.Tiwari



Plot No. A-531T.T.C. Industrial Area,M.I.D.C. Mahape,Navi Mumbai – 400 710Maharashtra



ashish.tiwari@superflowpumps.com



[https://www.exportersindia.com/super\\_industries](https://www.exportersindia.com/super_industries)